

INSTRUCTION MANUAL

ClimaGuard™ Outdoor Heat Exchanger *All Models*

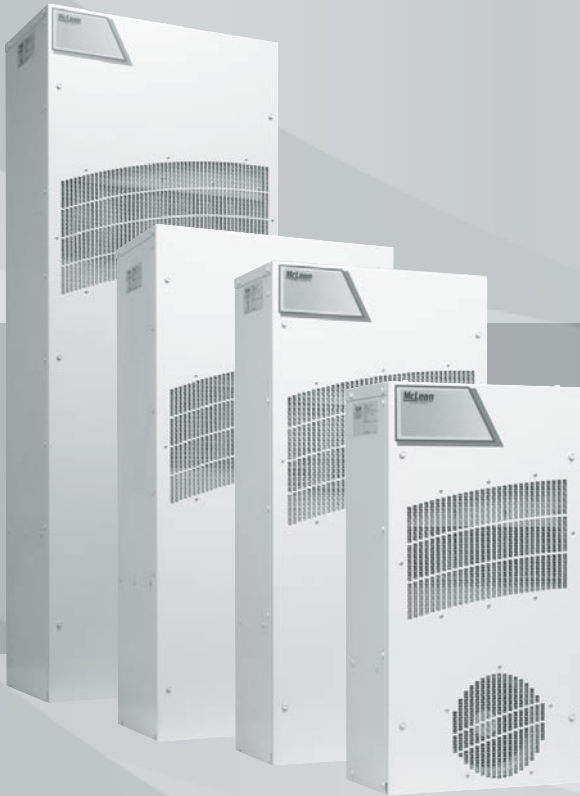

McLean®
COOLING TECHNOLOGY

A Pentair Company

*Protecting Electronics.
Exceeding Expectations.™*

MAI

5736 North Michigan Road
Indianapolis, IN 46228

317-257-6811

317-257-1590 fax

www.McLeanParts.net

10-1008-221-Rev. 3

INSTRUCTION MANUAL

TABLE OF CONTENTS

Receiving the Heat Exchanger	1
Testing the Heat Exchanger	1
Installation	2
Principles of Operation.....	2
Maintenance	2
Design Data, Model Drawings	3-10
Mounting Instructions	3-10
Components List	11
Wire Diagrams	12
Trouble Shooting.....	13-14

NOTE: Some of the information in this manual may not apply if a special unit was ordered. If additional drawings for a special unit are necessary, they have been inserted. Contact MAI if further information is required.

RECEIVING THE HEAT EXCHANGER

Inspect the Heat Exchanger. Check for concealed damage that may have occurred during shipment. Look for dents, scratches, loose assemblies, etc. Damage evident upon receipt should be noted on the freight bill. Damage should be brought to the attention of the delivering carrier -- NOT to MAI- within 15 days of delivery. Save the carton and packing material and request an inspection. Then file a claim with the delivering carrier.

MAI cannot accept responsibility for freight damages; however, we will assist you in any way possible.

TESTING THE HEAT EXCHANGER

TEST FOR FUNCTIONALITY **BEFORE** MOUNTING THE HEAT EXCHANGER TO THE ENCLOSURE.

Refer to nameplate for proper electrical current requirements, and then connect power cord to a properly grounded power supply. Minimum circuit ampacity should be at least 125% of the amperage shown in the design data section for the appropriate model. No other equipment should be connected to this circuit to prevent overloading.

Operate the heat exchanger for several minutes. No excessive noise or vibration should be evident during this run period. Ambient air mover may not be energized at temperatures low enough to not require cooling. On DC powered units air movers may not always be running at full speed.

INSTALLATION

Step 1: Inspect heat exchanger. Verify functionality before mounting the heat exchanger, see Testing the Heat Exchanger on page 1.

Step 2: Determine if the unit is to be surface or recess mounted. Using the appropriate cutout dimensions shown in this manual, prepare the enclosure opening for either surface or recess mounting.

Step 3: Using the gasket kit provided, install gaskets to heat exchanger.

Step 4: Mount heat exchanger on enclosure using mounting screws provided. Torque screws to 25 in-lbs.

Step 6: Refer to unit nameplate for electrical requirements. Connect the power cord to a properly grounded power supply. Use of an extension cord is not recommended. Electrical circuit should be fused with slow blow or HACR circuit breaker.

PRINCIPLES OF OPERATION

Operating the heat exchanger below the minimum ambient temperature or above the maximum ambient temperatures indicated on the nameplate voids all warranties.

It is recommended that the warranty section of this manual be read in order to familiarize you with parameters of restricted operation.

MAINTENANCE

Air Movers

Air mover motors require no maintenance. All bearings are lubricated during manufacturing for the life of the motor.

If the ambient air mover should fail, it is not necessary to remove the heat exchanger from the cabinet or enclosure to replace it. The ambient air mover is mounted on a bulkhead and is easily accessible by removing the front cover.

Caution: Operation of the heat exchanger in areas containing airborne caustics or chemicals can rapidly deteriorate aluminum cores and air movers. Contact MAI for special recommendations.

Ambient Air In/Out Screens

In dirty environments the bug screens on the front cover may need to be cleaned periodically to maintain adequate cooling performance. The front cover should be removed from the heat exchanger and set aside for cleaning with water, air or scrubbed clean with a brush.

TX23 Series

25 Watts/°C (14 Watts/°F)

H x W x D: 23" (584) x 12" (305) x 7.11" (181)

Model	Voltage	Hz	Full Load Amps	Phase	Max Temp (°C/°F)	Min Temp (°C/°F)	Shipping Weight Lbs/Kgs
TX23-1424-XXX	24VDC		3.4		65/149	-40/-40	30/13.6
TX23-1448-XXX	48VDC		1.8		65/149	-40/-40	30/13.6
TX23-1416-XXX	115VAC	50/60	TBD	1	65/149	-40/-40	30/13.6
TX23-1426-XXX	230VAC	50/60	TBD	1	65/149	-40/-40	30/13.6

XXX will be replaced with a three-digit number designating all desired options. Consult the factory for specific model numbers.

TX23 Mounting Cutout Dimensions

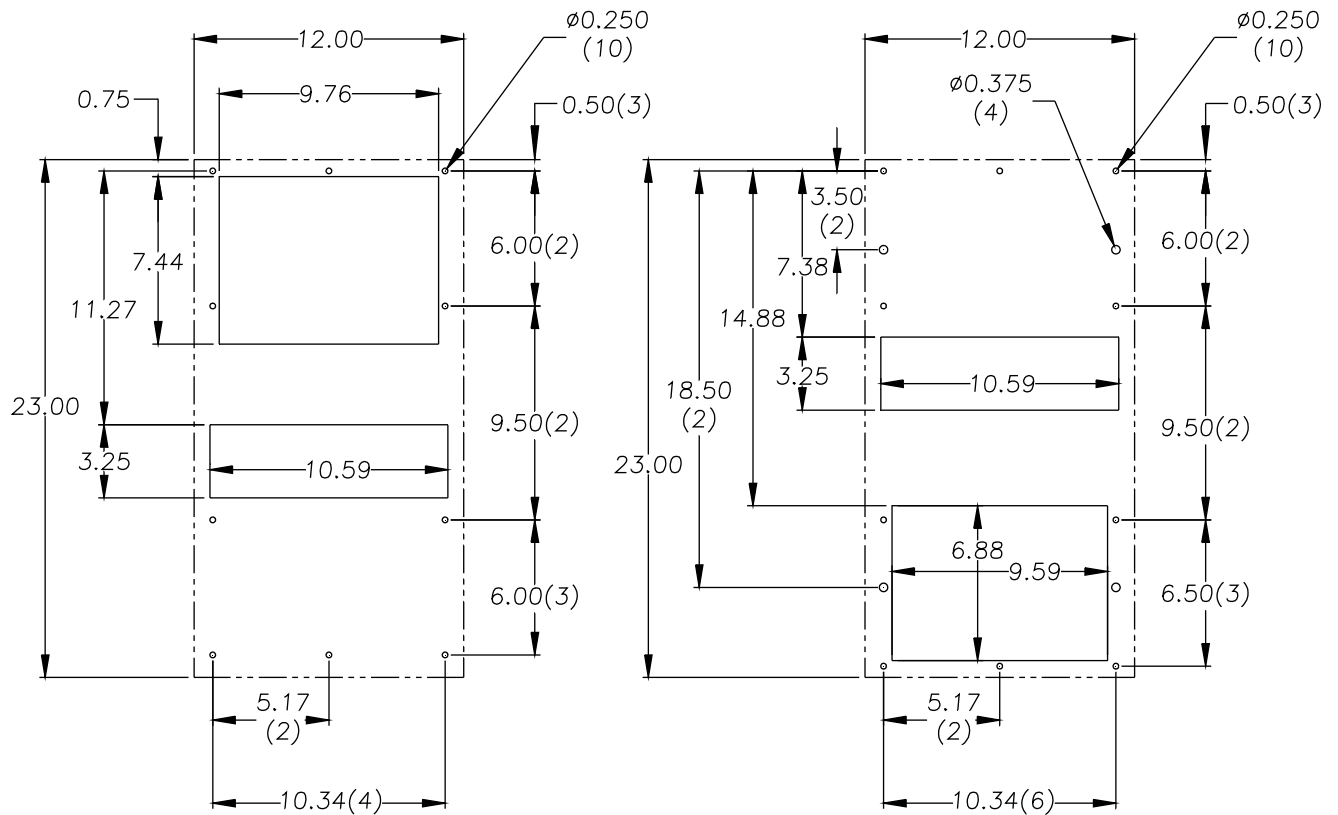

EXTERNALLY MOUNTED

INTERNALLY MOUNTED

CUTOUT INSTRUCTIONS (AS VIEWED FROM OUTSIDE OF ENCLOSURE)

NOTES:

1. DASHED LINES REPRESENT HEAT EXCHANGER.

TX23 DC Model Drawing

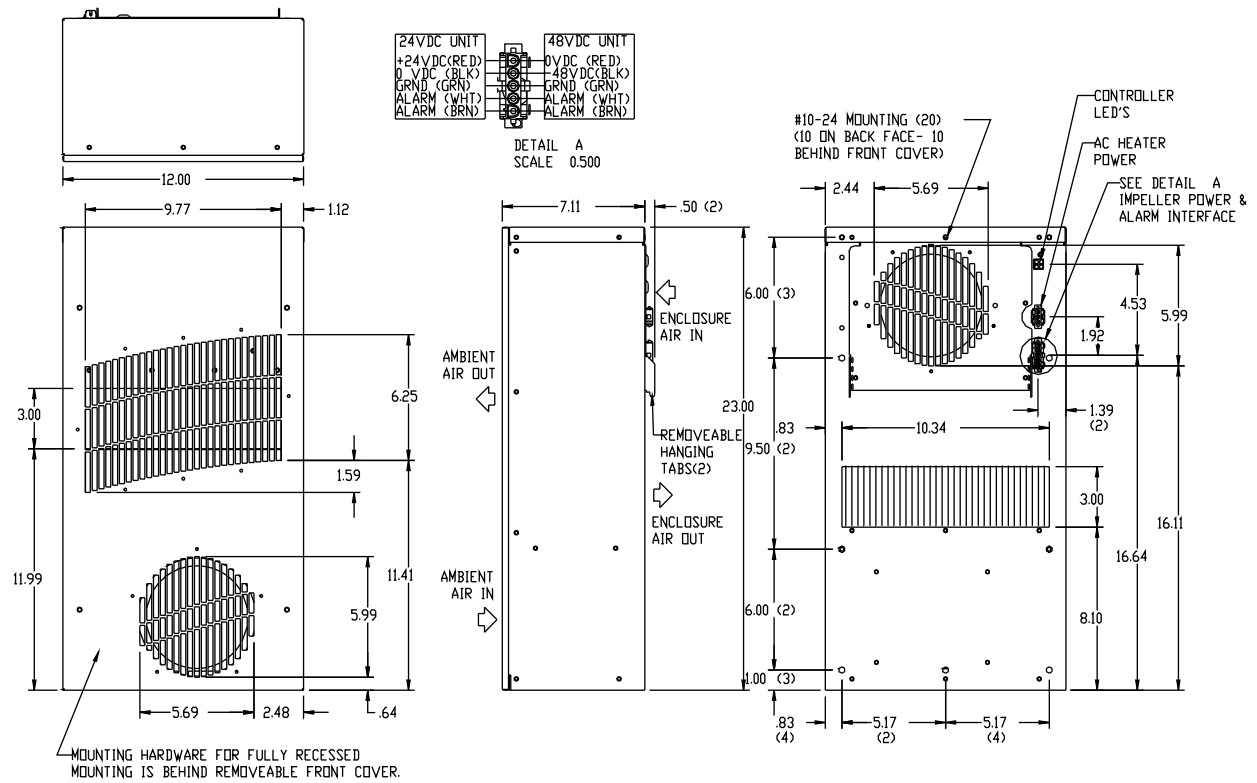

TX23 AC Model Drawing

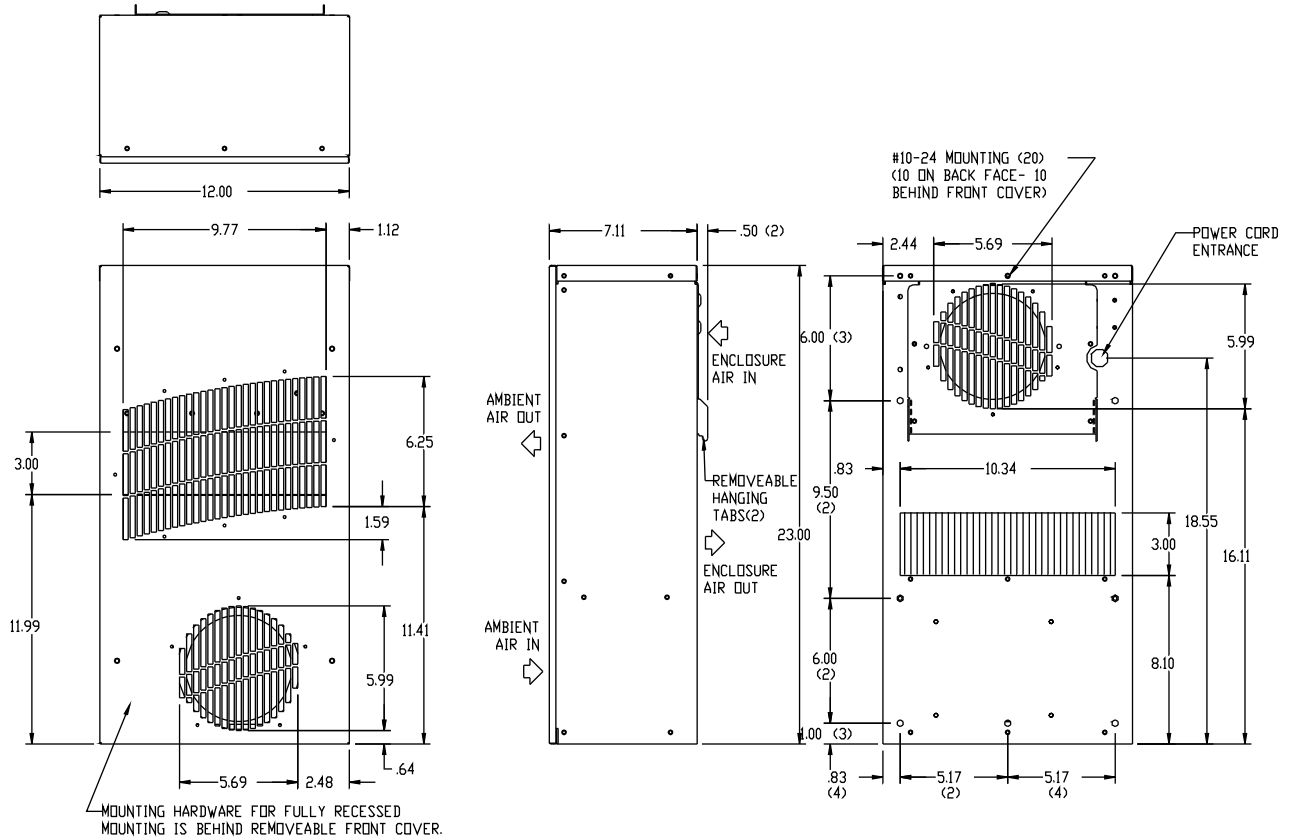

TX33 Series

50 Watts/°C (28 Watts/°F)

H x W x D: 33" (838) x 15.66" (398) x 8.11" (206)

Model	Voltage	Hz	Full Load Amps	Phase	Max Temp (°C/°F)	Min Temp (°C/°F)	Shipping Weight Lbs/Kgs
TX33-2824-XXX	24VDC		3.4		65/149	-40/-40	45/20.4
TX33-2848-XXX	48VDC		1.8		65/149	-40/-40	45/20.4
TX33-2816-XXX	115VAC	50/60	TBD	1	65/149	-40/-40	45/20.4
TX33-2826-XXX	230VAC	50/60	TBD	1	65/149	-40/-40	45/20.4

XXX will be replaced with a three-digit number designating all desired options. Consult the factory for specific model numbers.

TX33 Mounting Cutout Dimensions

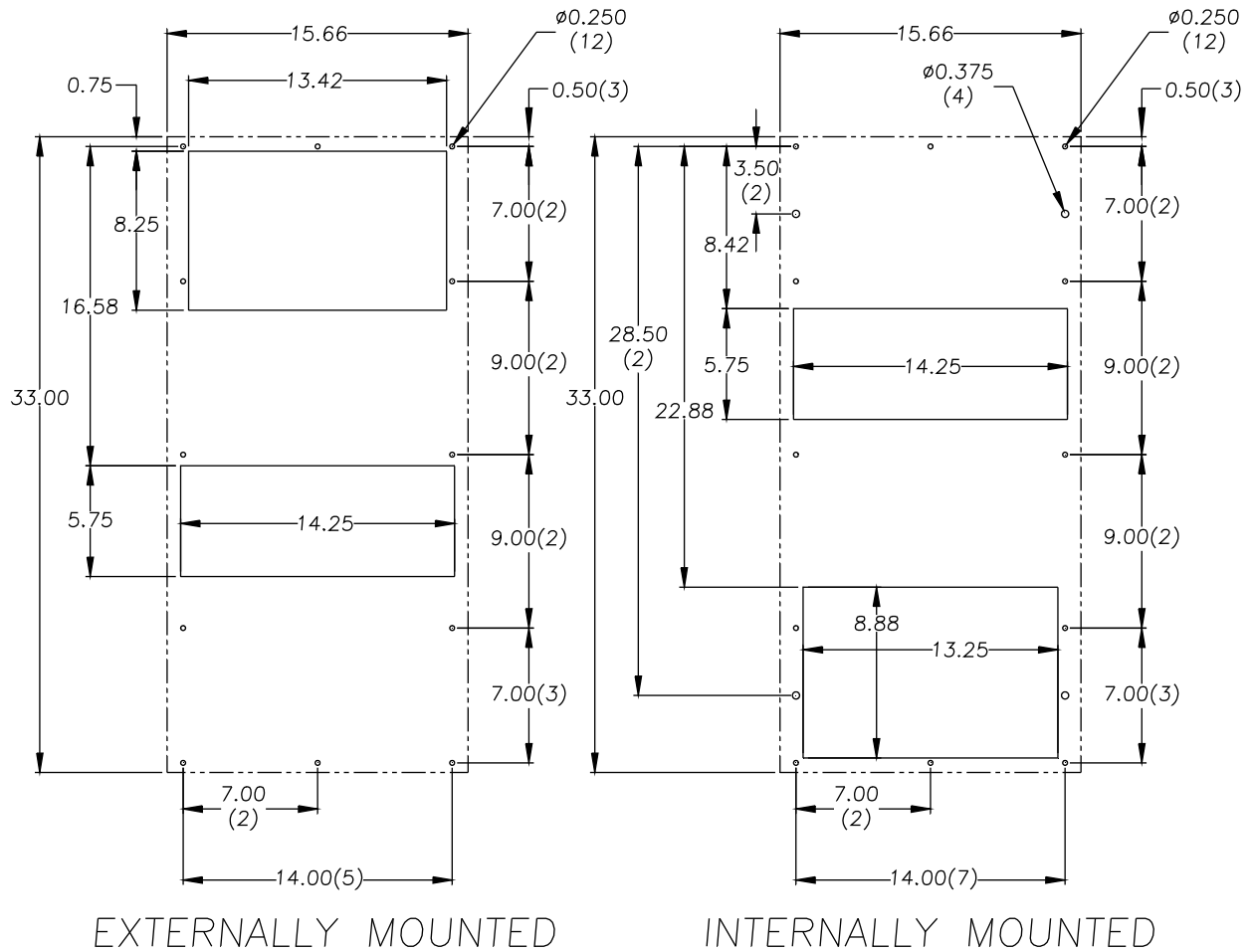

CUTOUT INSTRUCTIONS (AS VIEWED FROM OUTSIDE OF ENCLOSURE)

NOTES:
1. DASHED LINES REPRESENT HEAT EXCHANGER.

TX33 DC Model Drawing

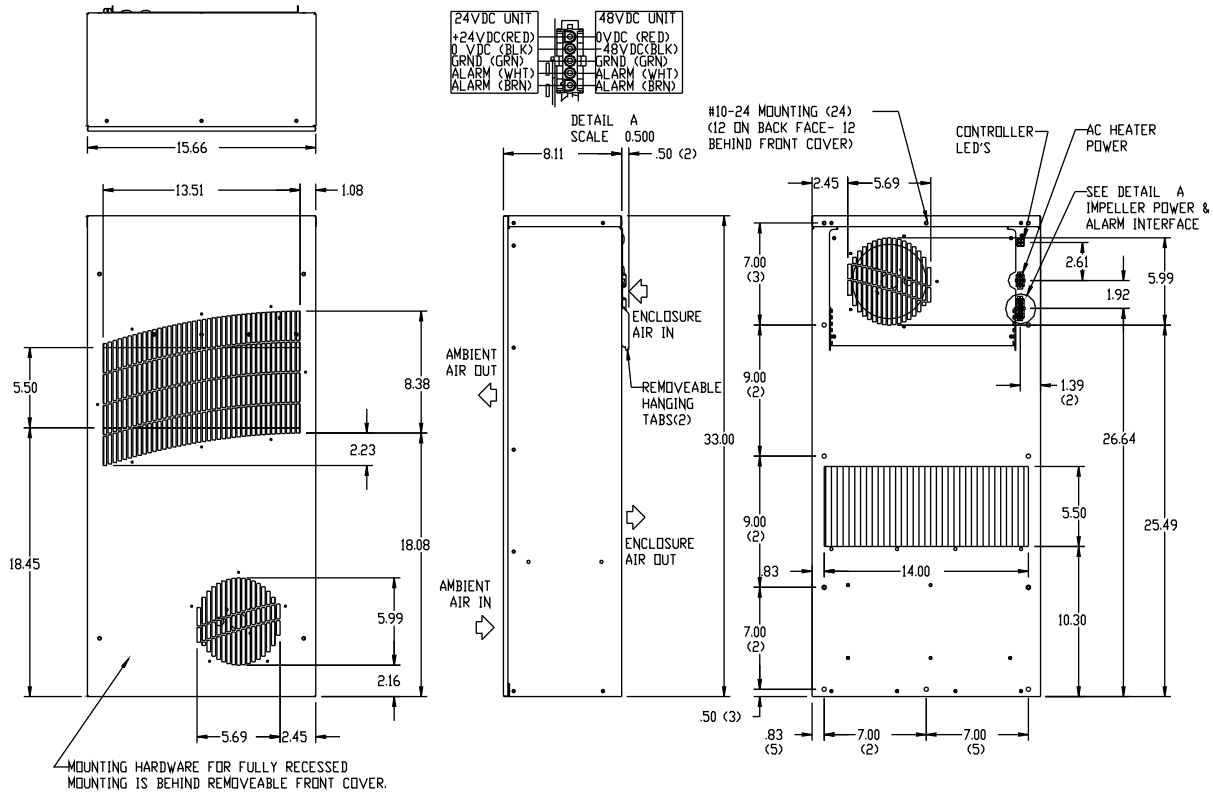

TX33 AC Model Drawing

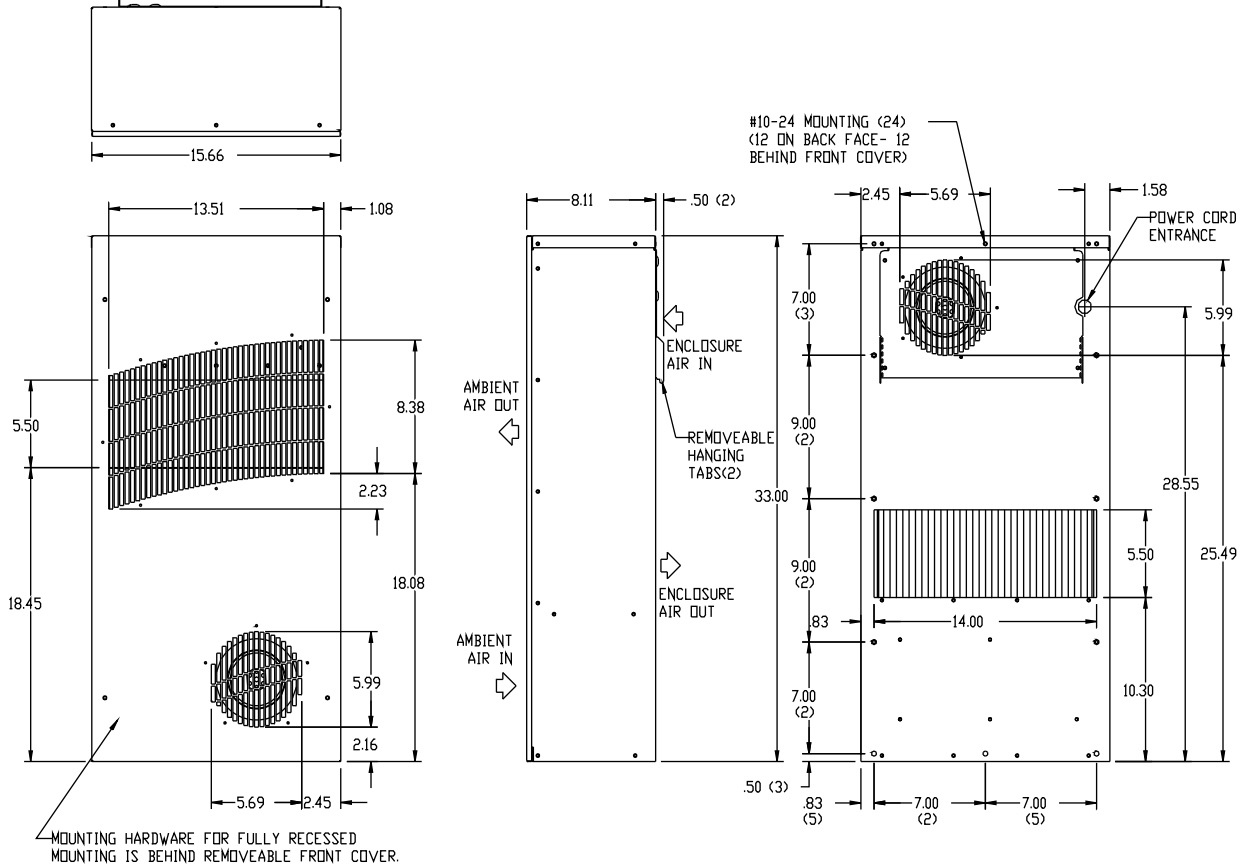

TX38 Series

100 Watts/°C (56 Watts/°F)

H x W x D: 38" (965) x 19.66" (499) x 10.11" (257)

Model	Voltage	Hz	Full Load Amps	Phase	Max Temp (°C/°F)	Min Temp (°C/°F)	Shipping Weight Lbs/Kgs
TX38-5624-XXX	24VDC		8.6		65/149	-40/-40	66/30
TX38-5648-XXX	48VDC		5.8		65/149	-40/-40	66/30
TX38-5616-XXX	115VAC	50/60	TBD	1	65/149	-40/-40	66/30
TX38-5626-XXX	230VAC	50/60	TBD	1	65/149	-40/-40	66/30

XXX will be replaced with a three-digit number designating all desired options. Consult the factory for specific model numbers.

TX38 Mounting Cutout Dimensions

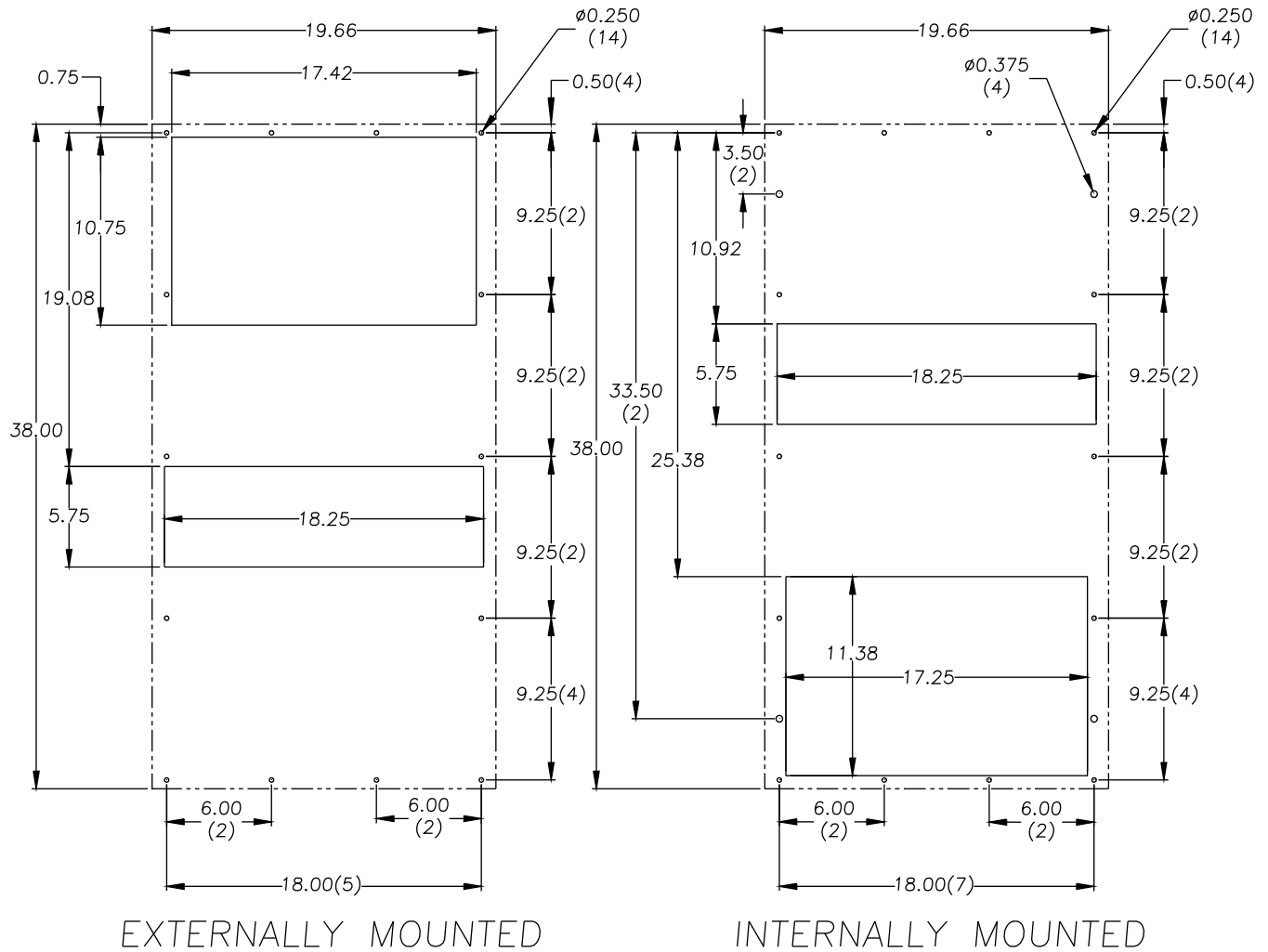

CUTOUT INSTRUCTIONS (AS VIEWED FROM OUTSIDE OF ENCLOSURE)

NOTES:
1. DASHED LINES REPRESENT HEAT EXCHANGER.

TX38 DC Model Drawing

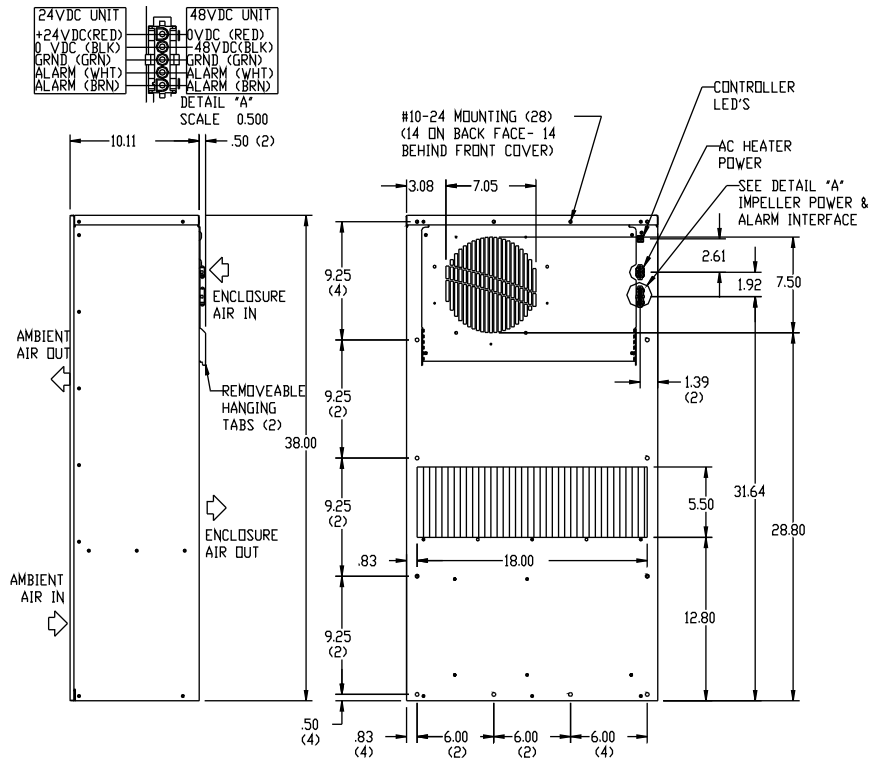
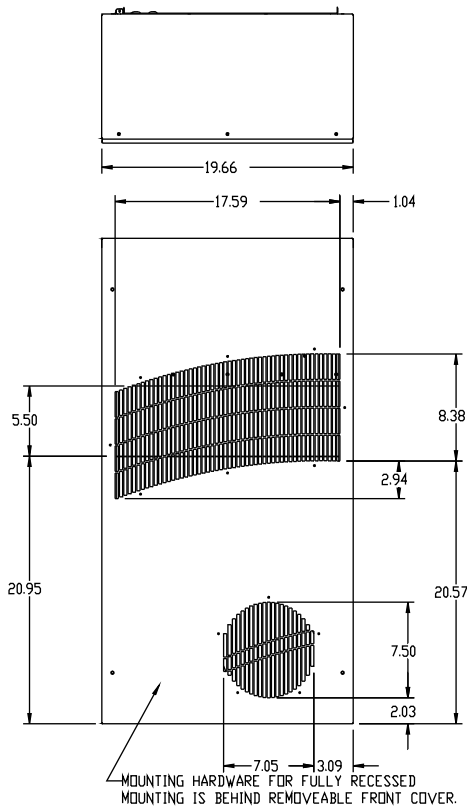

TX38 AC Model Drawing

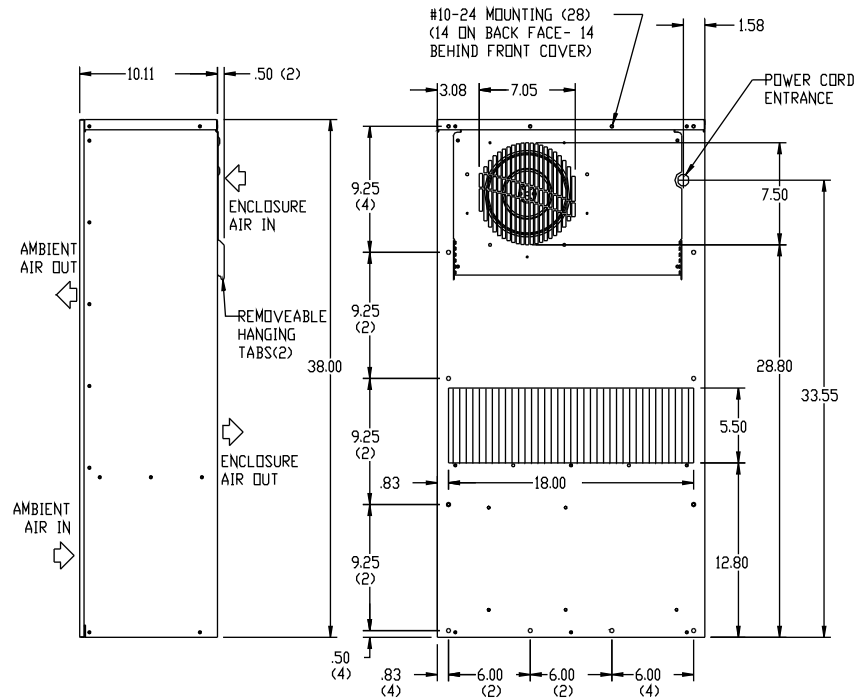
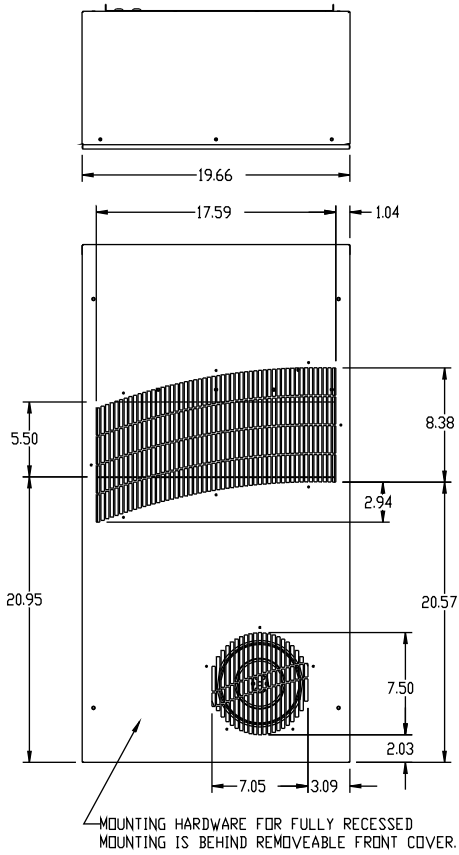

TX52 Series

150 Watts/°C (83 Watts/°F)

H x W x D: 52" (1321) x 19.66" (499) x 10.11" (257)

Model	Voltage	Hz	Full Load Amps	Phase	Max Temp (°C/°F)	Min Temp (°C/°F)	Shipping Weight Lbs/Kgs
TX52-8324-XXX	24VDC		21.1		65/149	-40/-40	100/45.3
TX52-8348-XXX	48VDC		7.8		65/149	-40/-40	100/45.3
TX52-8316-XXX	115VAC	50/60	4.3/6.7	1	65/149	-40/-40	100/45.3
TX52-8326-XXX	230VAC	50/60	2.2/3.4	1	65/149	-40/-40	100/45.3

XXX will be replaced with a three-digit number designating all desired options. Consult the factory for specific model numbers.

TX52 Mounting Cutout Dimensions

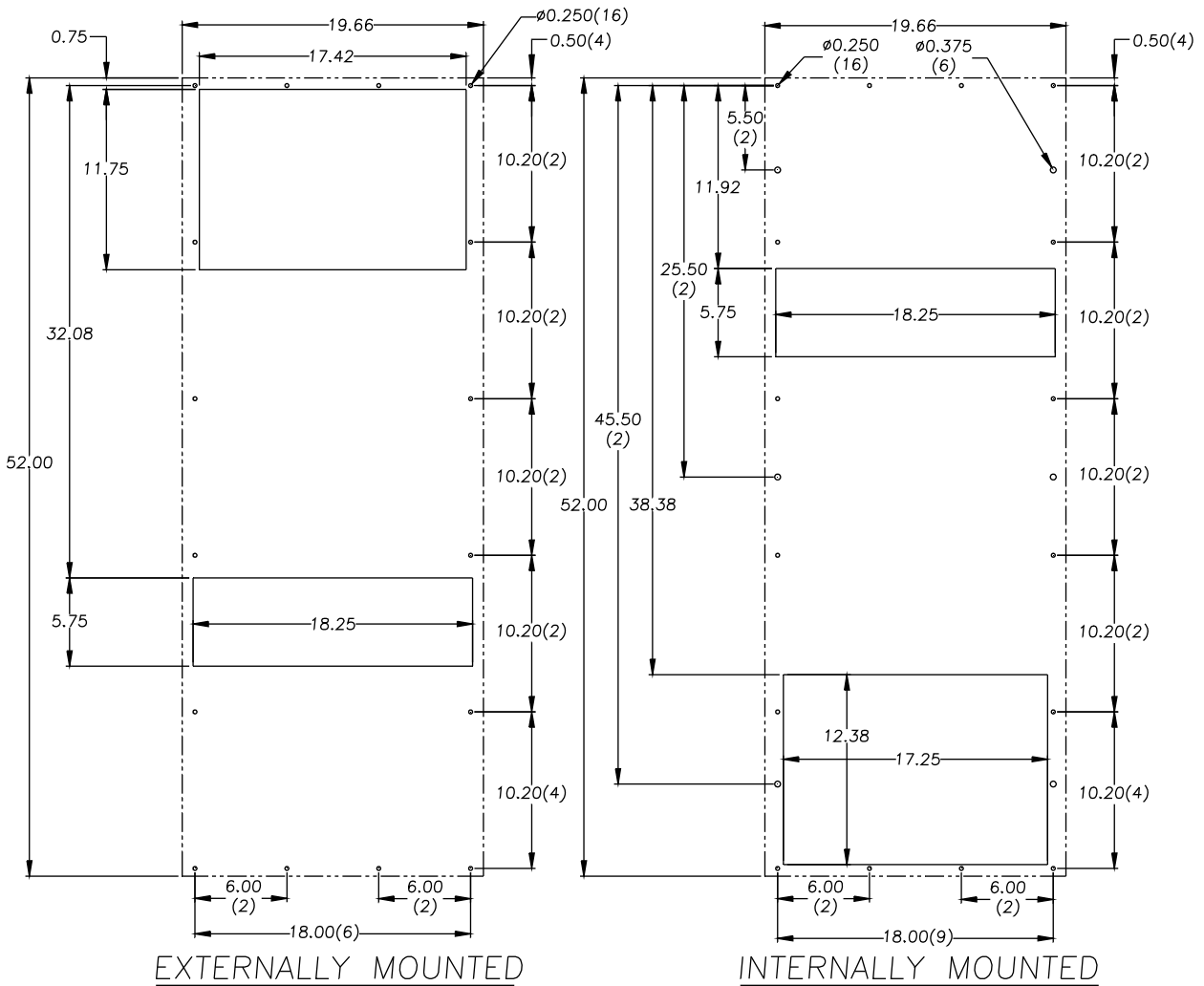

CUTOUT INSTRUCTIONS (AS VIEWED FROM OUTSIDE OF ENCLOSURE)

NOTES:
1. DASHED LINES REPRESENT HEAT EXCHANGER.

TX52 DC Model Drawing

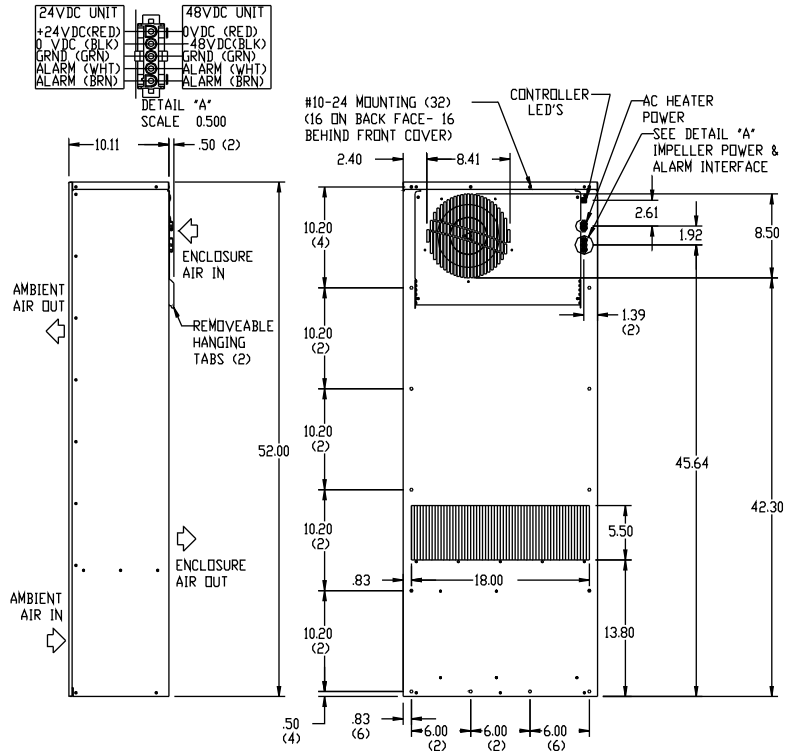
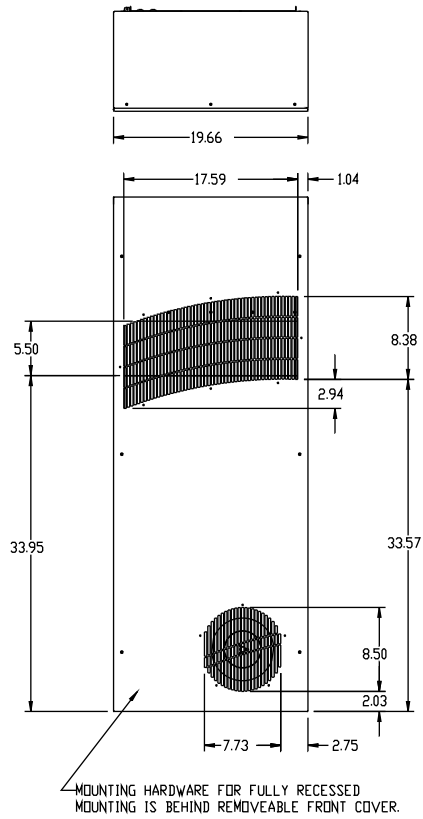

TX52 AC Model Drawing

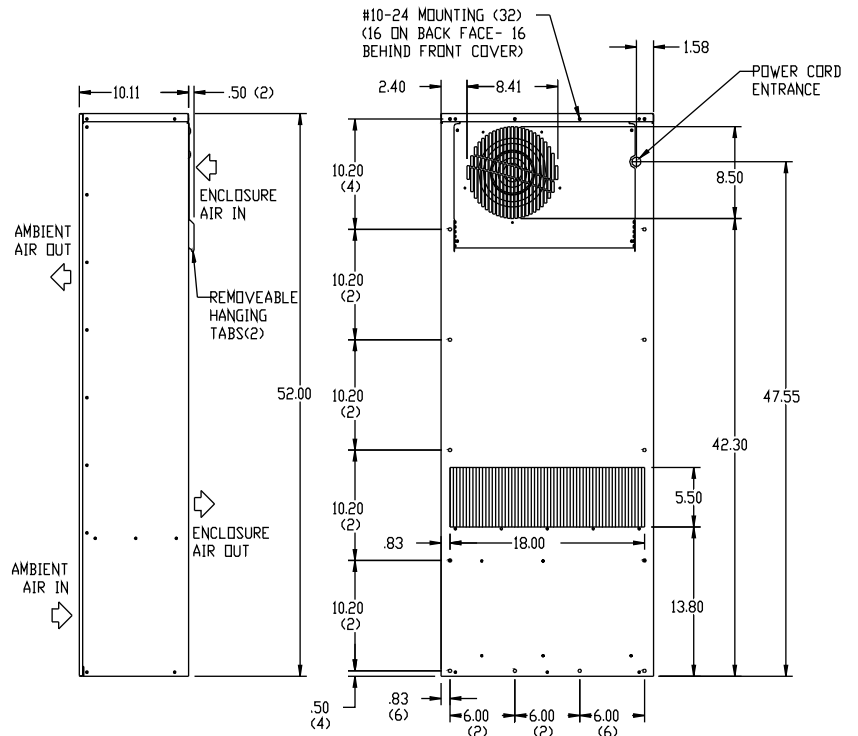
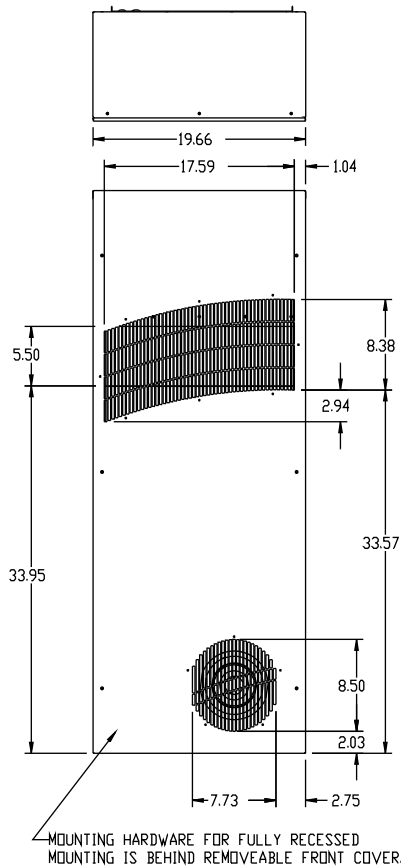

TX23 Components List

Part Description	Part Number			
	24VDC	48VDC	115VAC	230VAC
Air Movers	10-1091-64	10-1091-55	12-1012-01	12-1012-02
Controller, Generic (may vary w/options)	E117E004	E117E004	NA	NA
Thermostat	NA	NA	10-1061-16	10-1061-16
Service Cord / Harness	09-3001-89	09-3001-89	52-6035-138	52-6035-139

TX33 Components List

Part Description	Part Number			
	24VDC	48VDC	115VAC	230VAC
Air Movers	10-1091-64	10-1091-55	10-1091-130	10-1091-131
Controller, Generic (may vary w/options)	E117E004	E117E004	NA	NA
Thermostat	NA	NA	10-1061-16	10-1061-16
Capacitors	NA	NA	S-1353-1	52-6084-02
Service Cord / Harness	09-3001-89	09-3001-89	52-6035-138	52-6035-139

TX38 Components List

Part Description	Part Number			
	24VDC	48VDC	115VAC	230VAC
Air Movers	10-1091-12	10-1091-109	10-1091-132	10-1091-133
Controller, Generic (may vary w/options)	E117E000	E117E000	NA	NA
Thermostat	NA	NA	10-1061-16	10-1061-16
Capacitors	NA	NA	52-6031-03	52-6084-05
Service Cord / Harness	09-3001-89	09-3001-89	52-6035-138	52-6035-139

TX52 Components List

Part Description	Part Number			
	24VDC	48VDC	115VAC	230VAC
Air Movers	10-1091-125	10-1091-126	10-1091-134	10-1091-135
Controller, Generic (may vary w/options)	E117E002	E117E006	NA	NA
Thermostat	NA	NA	10-1061-16	10-1061-16
Capacitors	NA	NA	52-6031-03	52-6084-05
Service Cord / Harness	09-3001-96	09-3001-89	52-6035-138	52-6035-139

TX DC Wire Diagram (see label on unit for actual options)

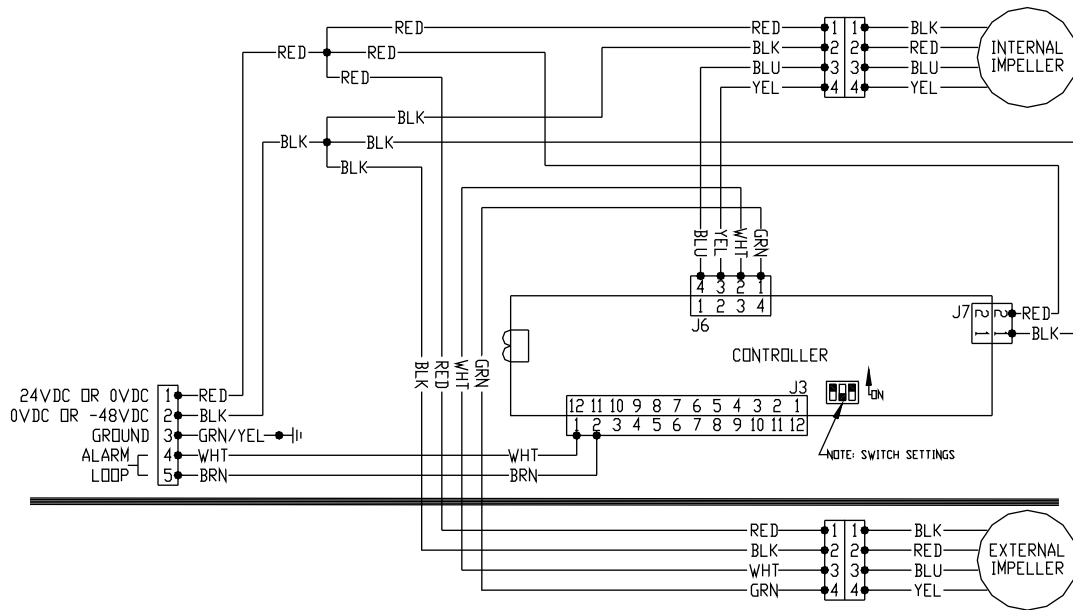

TX23 AC Wire Diagram (see label on unit for actual options)

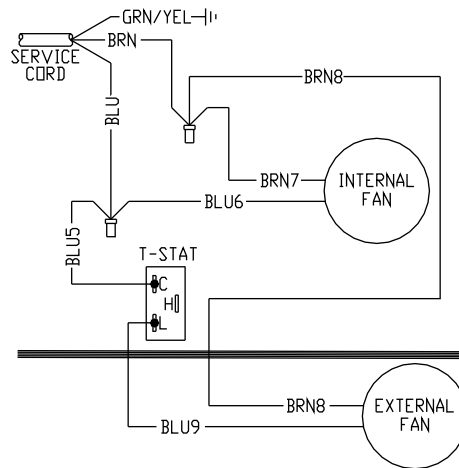

TX33, TX38, TX52 AC Wire Diagram (see label on unit for actual options)

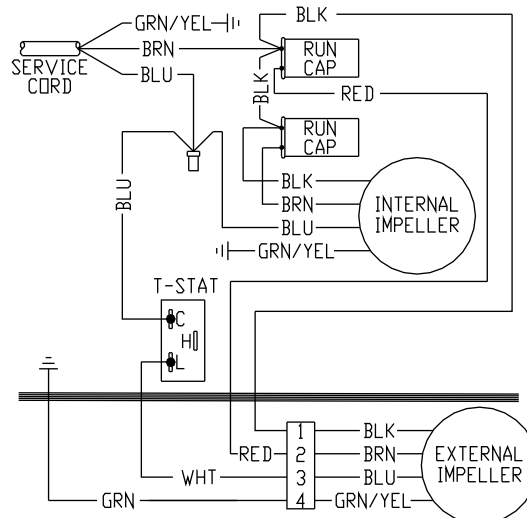

TROUBLE SHOOTING – AC Units

1. Check manufacturer's nameplate located on the unit for correct power supply.
2. Unit blows fuses or breakers.

Under sized fuse/breaker or not time delayed.
Short in system.

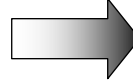

**Repair or Replace
defective part**

3. Turn the power to the unit on. The enclosure air mover should come on. Is there airflow?
YES, proceed to step # 4.

NO, possible: Open motor winding
 Stuck air mover motor
 Obstructed wheels/blades



**Repair or Replace
defective part**

4. Check thermostat setting? Adjust thermostat to the lowest setting. This should turn both air movers on. Did both air movers come on when the thermostat was turned down?
YES, proceed to step #5.

NO, possible: Defective thermostat



Replace part

5. Are both air movers running? If not the unit will not cool properly.
6. Check ambient air mover for airflow. Is there airflow?

YES, proceed to step # 7.

NO, possible: Defective thermostat
 Open motor winding
 Stuck air mover motor
 Obstructed wheels/blades

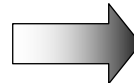

**Repair or Replace
defective part**

7. To check for a bad thermostat. Turn power to the unit off. Remove access cover, place both thermostat wires onto one terminal (replace access cover for safety). This will bypass the switch in the thermostat. Turn the power on. If both air movers come on, the thermostat needs to be replaced.

For additional technical information (i.e., amp draw, temperatures) contact MAI at 317-257-6811 or Sales@McLeanParts.net.

TROUBLE SHOOTING – DC Units

1. Check manufacturer's nameplate located on the unit for correct power supply.
2. Unit blows fuses or breakers.

Under sized fuse/breaker or not time delayed.
Short in system.



Repair or Replace defective part

3. Turn the power to the unit on.
4. Press the Quick-Test button (located above the LED's on the enclosure side of the unit). The unit will cycle through a series of self-diagnostic tests to verify proper operation of components.

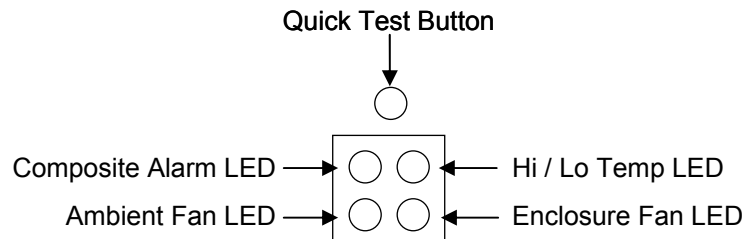

5. Do all LED's clear to GREEN following the self test? RED indicates a fault.
YES, unit is working properly.

NO, identify which alarm is activated:

Note the Composite Alarm LED will also light if any other alarm activates.

RED Alarm LED

Possible Cause

Solution

Ambient air mover
OR
Enclosure air mover

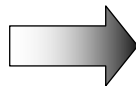

Open motor winding
Stuck air mover motor
Obstructed blades



Repair or Replace defective part

Hi / Lo Temp

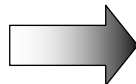

If the enclosure temperature is outside the nameplate temperature range, the Hi / Lo Temp alarm will activate.

Composite Alarm Only

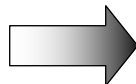

Controller Temperature Sensor Failure

Repair or Replace defective part

For additional technical information (i.e., amp draw, temperatures) contact MAI at 317-257-6811 or sales@McLeanParts.net.

*Protecting Electronics.
Exceeding Expectations.™*

MAI

5736 North Michigan Road

Indianapolis, IN 46228

317-257-6811

317-257-1590 fax



McLean[®]
COOLING TECHNOLOGY

A Pentair Company

www.McLeanParts.net